

minnow

Pickup Pod

Cubby System MPP Series

Installation and Operating Manual

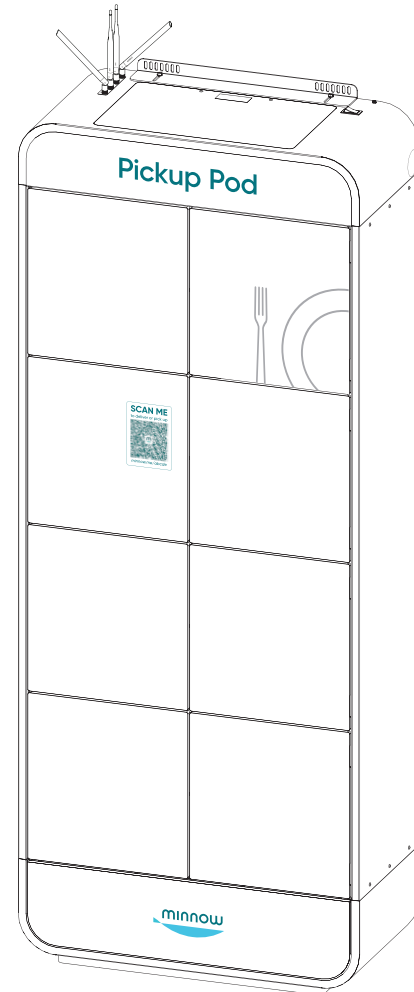

⚠ WARNING

Do not operate this equipment unless you have read and understood the contents of this manual! Failure to follow the instructions contained in this manual may result in serious injury or death. This manual contains important safety information concerning the maintenance, use, and operation of this product. If you're unable to understand the contents of this manual, please bring it to the attention of your supervisor. Keep this manual in a safe location for future reference.

⚠ AVERTISSEMENT

Ne pas utiliser cet équipement sans avoir lu et compris le contenu de ce manuel ! Le non-respect des instructions contenues dans ce manuel peut entraîner de graves blessures ou la mort. Ce manuel contient des informations importantes concernant l'entretien, l'utilisation et le fonctionnement de ce produit. Si vous ne comprenez pas le contenu de ce manuel, veuillez le signaler à votre supérieur. Conservez ce manuel dans un endroit sûr pour pouvoir vous y référer plus tard.

Important Owner Information	2	Operation	9
Introduction	2	General.....	9
Important Safety Information	3	Maintenance	10
Model Description	4	General.....	10
Specifications	5	Daily Cleaning.....	10
Plug Configurations.....	5	Troubleshooting Guide	11
Electrical Rating Chart.....	5	Limited Warranty	Back Cover
Dimensions.....	5		
Cubby Interior Dimensions.....	5		
Installation	6		
General.....	6		
Installing the Pickup Pod.....	6		
Setting Up the Pickup Pod for Operation.....	8		

IMPORTANT OWNER INFORMATION

Record the model number, serial number, voltage, and purchase date of the unit in the spaces below (specification label located near the power inlet on the back of the unit). Please have this information available when calling Minnow for service assistance.

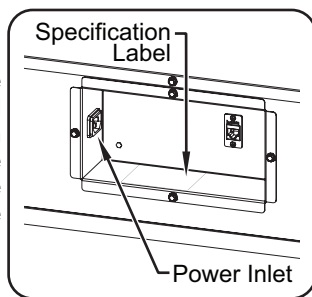

Business Hours: 9:00 AM to 5:00 PM Monday–Friday, Pacific Time (PT)

Telephone: 503-897-9061

email: support@minnowpod.com

Knowledge Base: www.minnowpod.com/support/

Additional information can be found by visiting our web site at www.minnowpod.com.

Model No. _____

Serial No. _____

Voltage _____

Date of Purchase _____

INTRODUCTION

Minnow Pickup Pods provide safe, secure, contact-free access to pickup and delivery orders. They are self-service and can be placed in workplaces, office buildings, and multi-family residential buildings.

Minnow Pickup Pods are products of extensive research. The materials used were selected for maximum durability, attractive appearance, and optimum performance. Every unit is inspected and tested thoroughly prior to shipment.

This manual provides the installation, safety, and operating instructions for Minnow Pickup Pods. Minnow recommends all installation, operating, and safety instructions appearing in this manual be read prior to installation or operation of the unit.

Safety information that appears in this manual is identified by the following signal word panels:



WARNING indicates a hazardous situation which, if not avoided, could result in death or serious injury.



CAUTION indicates a hazardous situation which, if not avoided, could result in minor or moderate injury.



NOTICE is used to address practices not related to personal injury.



Read the following important safety information before using this equipment to avoid serious injury or death and to avoid damage to equipment or property.

WARNING**ELECTRIC SHOCK HAZARD:**

- Plug unit into a properly grounded electrical receptacle of the correct voltage, size, and plug configuration. If plug and receptacle do not match, contact a qualified electrician to determine and install proper voltage and size electrical receptacle.
- Turn OFF power switch and unplug power cord before performing any cleaning, adjustments, or maintenance.
- DO NOT submerge or saturate with water. Unit is not waterproof. Do not operate if unit has been submerged or saturated with water.
- Unit is not weatherproof. Locate unit indoors in a temperature-controlled environment.
- Do not steam clean or use excessive water on unit.
- This unit is not “jet-proof” construction. Do not use jet-clean spray to clean this unit.
- Do not clean unit when it is energized.
- Do not clean unit with metal scouring pads. Metal pieces can break off pad and touch electrical components, creating risk of electric shock.
- Discontinue use if power cord is frayed or worn.
- This unit must be serviced by qualified personnel only. Service by unqualified personnel may lead to electric shock or burn.
- Use only Genuine Minnow/Hatco Replacement Parts when service is required. Failure to use Genuine Minnow/Hatco Replacement Parts will void all warranties and may subject operators of the equipment to hazardous electrical voltage, resulting in electrical shock or burn. Genuine Minnow/Hatco Replacement Parts are specified to operate safely in the environments in which they are used. Some aftermarket or generic replacement parts do not have the characteristics that will allow them to operate safely in Minnow/Hatco equipment.

EXPLOSION HAZARD: Do not store or use gasoline or other flammable vapors or liquids in the vicinity of this or any other appliance.

Install unit in accordance with installation instructions in this manual.

This unit is not designed for long-term food holding. Manage or dispose of food products held for longer than safe holding time in accordance with all local food code requirements.

Use extreme caution when moving and tipping unit during installation. Size and weight of unit create significant tip and pinch point hazards. Remain aware and keep clear of unit/pinch points while tipping to avoid serious injury.

WARNING

FIRE HAZARD AND ELECTRIC SHOCK HAZARD: Replace power cord with Minnow/Hatco Replacement Part 02.18.757.00 only.

Make sure all operators have been instructed on the safe and proper use of the unit.

This unit is not intended for use by children or persons with reduced physical, sensory, or mental capabilities. Ensure proper supervision of children and keep them away from the unit.

This unit has no “user-serviceable” parts. If service is required on this unit, contact Minnow at: support@minnowpod.com

CAUTION

Locate unit in an area that is convenient for use. Location should be level to prevent unit or its contents from falling accidentally and strong enough to support weight of unit and contents.

Do not move or relocate unit for cleaning. Unit is bulky and heavy.

Do not place anything on top of unit; doing so may subject personnel to injury or could damage unit.

Do not store any materials or items inside unit when not in use.

Never use steel pads, wire brushes, or scrapers to clean unit.

NOTICE

Unit must be level for doors to function properly.

Do not lay unit on its front side. Damage to doors could occur.

Use non-abrasive cleaners and cloths only. Abrasive cleaners and cloths could scratch finish of unit, marring its appearance and making it susceptible to soil accumulation. DO NOT use cleaners such as acetone, Soft Scrub®, Bar Keepers Friend®, etc.

Clean unit daily to avoid malfunctions and maintain sanitary operation.

Model MPP-8I

Minnow Pickup Pods are designed to hold pickup and delivery orders securely while allowing quick, safe, and contact-free access. Each unit features eight insulated cubbies, individually-locked doors, a Power I/O (on/off) switch, and a 6' (1829 mm) detachable power cord with plug. Pickup Pods are available in accent colors of charcoal or bronze.

Except for the Power I/O switch, operation of the Pickup Pod is completely web-based. The web-based app is accessed easily by scanning the QR Code on the front of the unit. The Pickup Pod can be operated with the Minnow-supplied system or integrated with certain outside vendor's Point-Of-Sale (POS) systems.

Model MPP-8I is designed to be installed on the floor against a wall and includes a wall anchoring bracket for secure installation. Four adjustable feet allow leveling of the unit for proper alignment and smooth operation of the cubby doors.

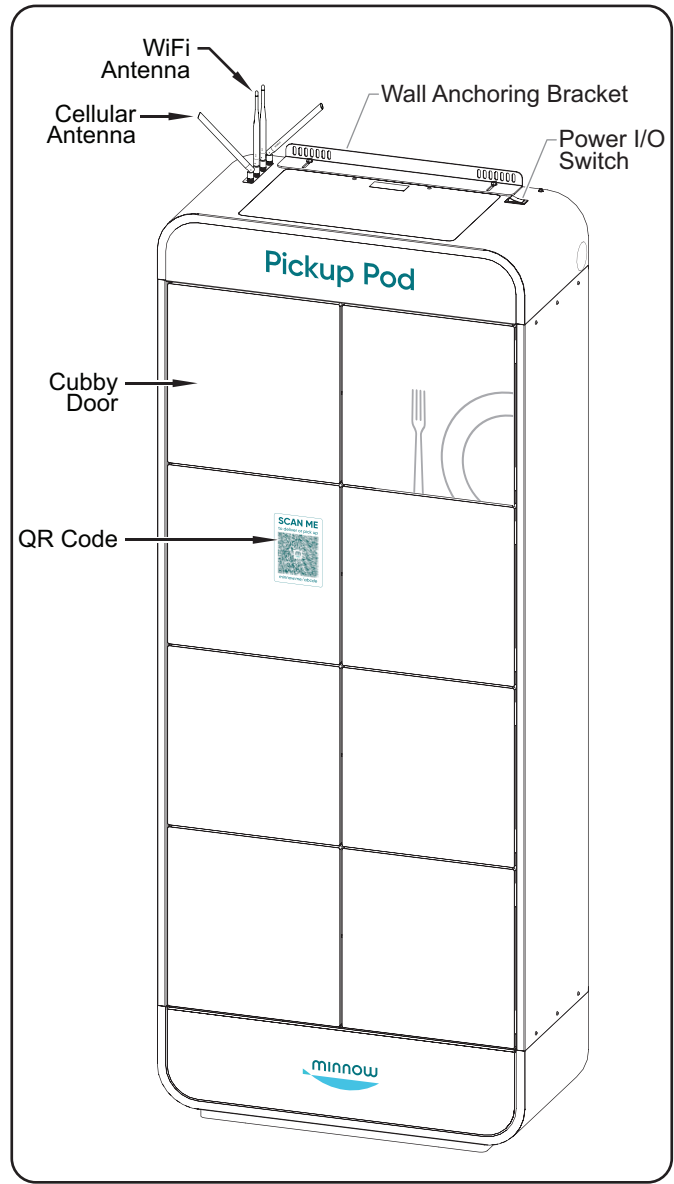

Model MPP-8I

Plug Configurations

Units are supplied from the factory with a detachable power cord and plug. Plugs are supplied according to the application.



ELECTRIC SHOCK HAZARD: Plug unit into a properly grounded electrical receptacle of the correct voltage, size, and plug configuration. If plug and receptacle do not match, contact a qualified electrician to determine and install proper voltage and size electrical receptacle.

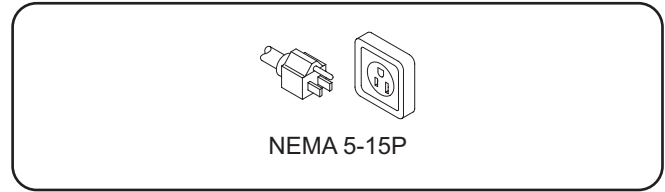

Plug Configurations

NOTE: Receptacle not supplied by Minnow.

NOTE: The specification label is located near the power inlet on the back of the unit. See the label for the serial number and verification of unit electrical information.

Electrical Rating Chart

Model	Voltage	Watts	Amps	Plug Configuration	Unit Weight
MPP-8I	120	90	0.75	NEMA 5-15P	274 lbs. (124 kg)

Dimensions

Model	Width (A)	Depth (B)	Overall Height (C)	Unit Height (D)
MPP-8I	31-15/16" (810 mm)	16" (406 mm)	86-1/8" (2187 mm)	77-11/16" (1973 mm)

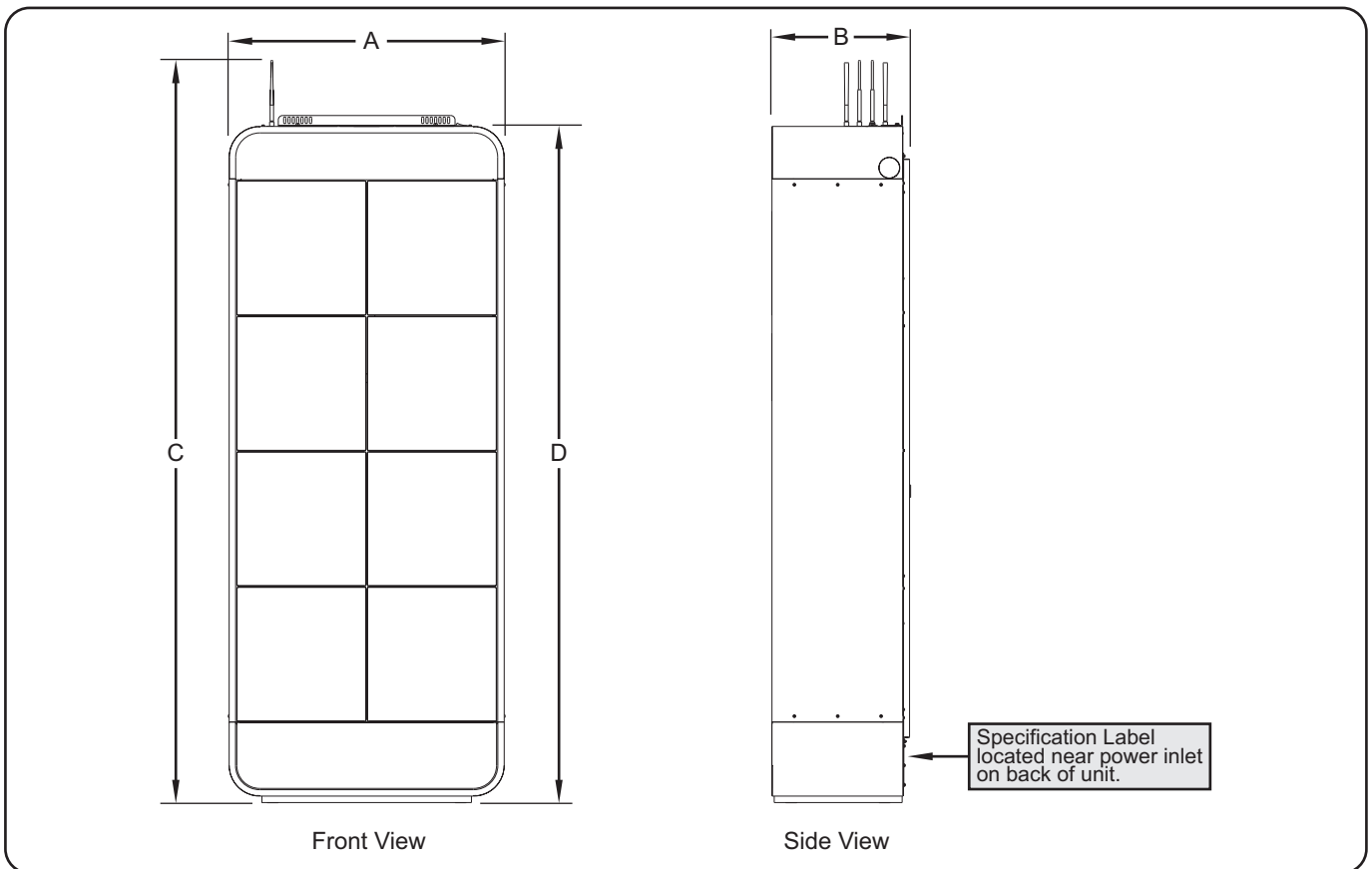

Cubby Interior Dimensions

Width	Depth	Height
13-11/16" (348 mm)	14-7/16" (367 mm)	15" (380 mm)

General

Minnow Pickup Pods are shipped mostly assembled. Care should be taken when unpacking the shipping carton to avoid damage to the unit. Use the following procedures to complete assembly and install a Pickup Pod.



ELECTRIC SHOCK HAZARD: Unit is not weatherproof. Locate unit indoors in a temperature-controlled environment.



Locate unit in an area that is convenient for use. Location should be level to prevent unit or its contents from falling accidentally and strong enough to support weight of unit and contents.



Unit must be level for doors to function properly.

Do not lay unit on its front side. Damage to doors could occur.

NOTE: Due to the size and weight of the unit, use the proper number of people for installation based on the weight of the unit.

1. Inspect the shipping container for obvious signs of transit damage. If damaged, take photos of the damage and inform the freight company immediately. **CAUTION! Stop! Do not attempt to use a damaged unit. Contact Minnow for assistance.**
2. Move the unit close to the final installation location.
 - The unit is shipped in a horizontal position, and will need to be tipped up to its normal, vertical position. Make sure there is enough space to tip up the unit near the installation location.
3. Cut and remove the shipping bands from around the packaging, then remove the packaging.
4. Remove any loose components/accessories from the shipping container. The following loose components are included in an “Accessory” box in every Minnow Pickup Pod:
 - Power cord
 - Wall anchoring hardware kit
 - Antennas

NOTE: The leveling feet on the pickup pod are metal. To prevent scratching the floor, be very careful while moving the unit during installation. Consider placing something underneath the unit to protect the floor.

5. With the help of several people, carefully tip up the unit to its vertical position.
6. Remove the tape and protective packaging from all surfaces of the unit.
7. Inspect the unit for freight damage such as dents or scratches on the exterior, doors, or inside the cubbies. If damaged, take photos of the damage and inform the freight company immediately.

8. Perform the “Installing the Pickup Pod” procedure.
9. Perform the “Setting up the Pickup Pod for Operation” procedure.

Installing the Pickup Pod

The Pickup Pod is a floor standing unit that needs to be secured to a wall using the wall anchoring bracket. Use the following procedures to install a Pickup Pod in an appropriate location.

Tools Required

- | | |
|-------------------------|-----------------------|
| #2 Phillips Screwdriver | Flat Head Screwdriver |
| Level | Adjustable Wrench |
| Cordless Drill | 5/16” Drill Bit |
| Hammer | Step Ladder |

Positioning the Pickup Pod



Use extreme caution when moving and tipping unit during installation. Size and weight of unit create significant tip and pinch point hazards. Remain aware and keep clear of unit/pinch points while tipping to avoid serious injury.

1. Using the appropriate number of people, place the unit in the desired location.
 - Locate the unit indoors in a temperature-controlled environment and in an area that is convenient for use. Installation locations above ground and near windows will allow for better cellular connectivity.
 - Make sure the floor is level and the unit is placed in front of an appropriate wall for installation of the anti-tip wall anchoring bracket.
 - Make sure a grounded electrical receptacle of the correct voltage, size, and plug configuration is within three feet of the unit on the installation wall.
 - Make sure the cellular signal in the installation location is three bars or higher for all major mobile service providers. Users and delivery workers will be using mobile devices to open the cubby doors.
2. Level the unit, if necessary.
 - a. Remove the two (2) screws that secure the top access panel to the unit. Remove the panel. **WARNING! ELECTRIC SHOCK HAZARD—Removing top access panel exposes electrical components. Make sure power switch is OFF and unit is unplugged before removing panel.**
 - b. Pull up on the door release ring located just below the front, center of the top opening. All the cubby doors will open.

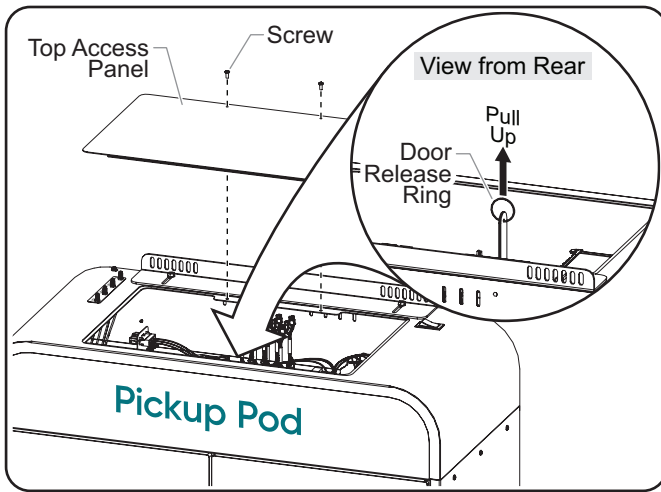

Opening the Cubby Doors

- c. Replace the top panel, and tighten the screws securely. **NOTICE: Replace top panel immediately after releasing doors. This will prevent dust and debris from entering electrical compartment.**
- d. Open the two bottom cubby doors (#7 and #8) completely to expose the bottom access panel screws.
- e. Remove the four (4) screws that secure the bottom access panel to the unit. Remove the panel:
 - Have someone hold the pod to prevent tipping.
 - Grasp the top, middle of the panel with both hands, and angle the top edge away from the unit until the sides of the panel clear the two open doors.

f. Using a level and the appropriate tool (flat blade screwdriver or 1/4" hex wrench), adjust the leveling feet until the unit is stable and level.

NOTE: If floor protection was used underneath the unit, it may need to be removed to ensure proper leveling.

- g. Replace the bottom access panel, and secure using the four (4) screws.
- h. Close all the cubby doors.

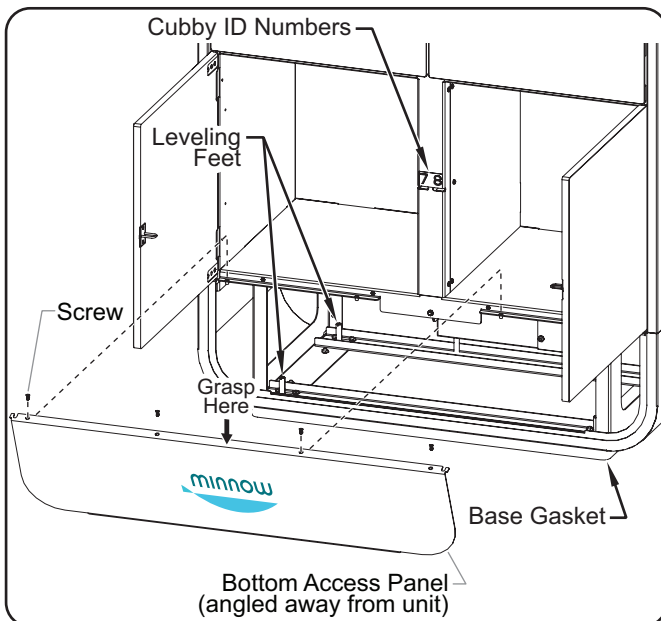

Leveling the Unit

Anchoring the Pickup Pod

Secure the Pickup Pod to the wall using the wall anchoring bracket. A hardware kit has been included for hollow wall installation.

NOTE: The following procedure is for hollow wall installation only. If studs are available in the wall that line up with at least one hole on each side of the anchoring bracket, use the appropriate fasteners to secure the bracket to the studs.

1. Remove any floor protection that was placed underneath the unit.
2. Loosen, but do not remove, the two (2) 3/8" bracket hex screws that secure the wall anchoring bracket to the top of the unit.
3. Slide the wall anchoring bracket so it is flush against the wall above the unit. Tighten the 3/8" hex screws securely.
4. Mark the outermost hole location on each side of the anchoring bracket onto the wall.
5. Being careful not to damage the floor, move the unit away from the wall to provide room for drilling.
6. Using a 5/16" drill bit, pre-drill the holes in the wall at the marked locations.

NOTE: For very hard wall materials, use a 3/8" drill bit for the pre-drilled holes.

7. Install the included plastic toggle anchors into each pre-drilled hole.
 - a. While holding the rim of the anchor with one hand, simultaneously push in the middle and squeeze together the wings of the anchor.
 - b. Using a hammer, tap an anchor into each pre-drilled hole until it is flush with the wall.
 - c. Insert the included toggle key into the anchor, and push the key firmly into the anchor to spread the wings of the anchor behind the wall.

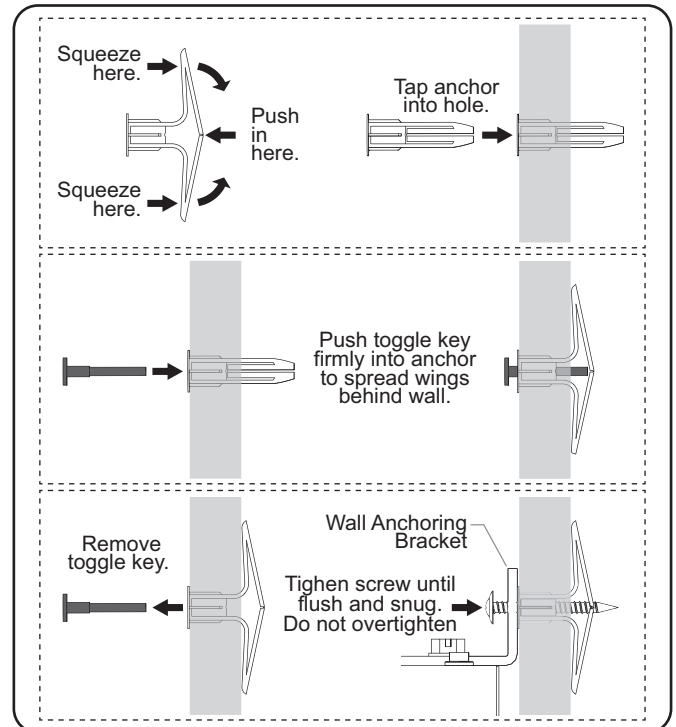

Using the Toggle Anchors

continued...

8. Clean up all dust and debris created by drilling and the installation of the toggle anchors.

9. Plug the female end of the detachable power cord into the power inlet on the back of the unit, near the bottom.

NOTE: If using ethernet to connect to the internet, plug the ethernet cable into the ethernet port near the power inlet.

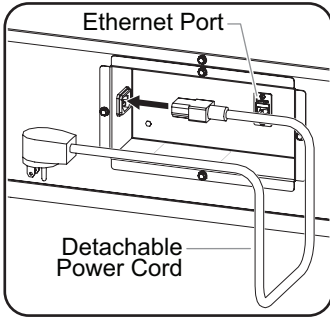

10. Being careful not to damage the floor, move the unit back to the installation location, and line up the holes on the mounting bracket with the toggle anchors.

11. Insert the included screws through the wall bracket and into the toggle anchors. Tighten until flush and snug. Do not overtighten.

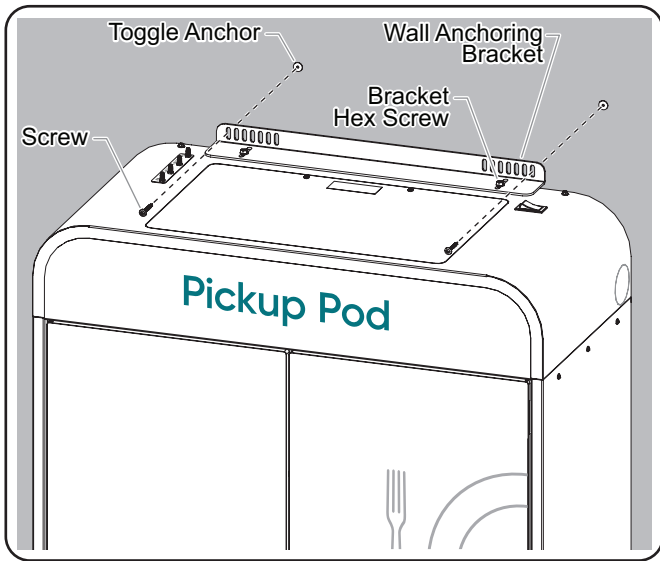

Anchoring the Unit to A Wall

Finishing Installation of the Pickup Pod

Prepare the Pickup Pod for setup and operation.

1. Install the cellular and WiFi antennas onto the antenna plate on top of the unit. The fittings on the plate are labeled.
 - Thread the two cellular (mobile) antennas onto the appropriate fittings until hand tight.
 - Thread the two WiFi antennas onto the appropriate fittings until hand tight.

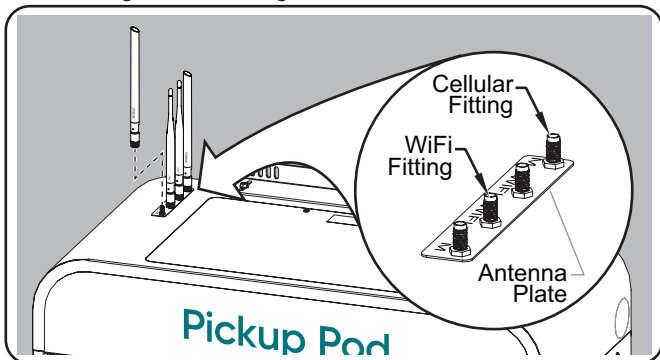

Installing the Antennas

2. Move the antennas to their proper positions.

- The cellular (mobile) antennas should be positioned at 45° angles, opposite from each other.
- The WiFi antennas should be positioned straight up.

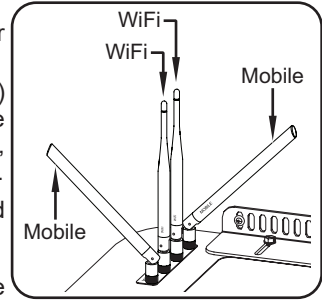

3. Plug the male end of the power cord into a properly grounded electrical receptacle of the correct voltage, size, and plug configuration. See the SPECIFICATIONS section for details.

Setting Up the Pickup Pod for Operation

The final steps in setting up a Pickup Pod for Operation include connecting the Pickup Pod to the internet, creating a Minnow Admin Account, and registering the Pickup Pod.

Connecting the Pickup Pod to the Internet

The Pickup Pod must be connected to a cellular or local network in order to communicate with the Minnow cloud software for administration and operation.

There are three options for network connection, listed below in the preferred order:

- Cellular Network—This is the default method and is set up before the Pickup Pod arrives onsite. Once power is on, the Pickup Pod will connect automatically to the Minnow cloud software. Pickup Pods currently use the Verizon 4G cellular network.
- WiFi—For WiFi connection setup instructions, access the link below: [Connect Pickup Pod to WiFi](#)

- Ethernet—This is a hardwired connection and requires an ethernet cable that connects the Pickup Pod to a modem/router. The ethernet port is located on the back of the unit, near the power inlet. For ethernet setup instructions, access the link below:

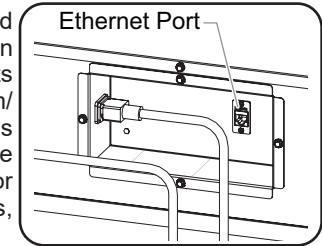

[Connect Pickup Pod to Ethernet](#)

Creating a Minnow Admin Account

For information on how to create a Minnow Admin Account, access the link below:

[Creating an Admin Account](#)

Registering a Pickup Pod

For information on how to register a Pickup Pod, access the link below:

[Registering a Pickup Pod](#)

General

Operation of a Minnow Pickup Pod is completely web-based through the Minnow cloud software. Make sure to perform the “Setting Up the Pickup Pod for Operation” procedure in the INSTALLATION section before proceeding.



WARNING

Read all safety messages in the IMPORTANT SAFETY INFORMATION section before operating this equipment.

Administrator/Owner Operation

Administrators/owners control the operation of the Pickup Pod by accessing their personal Admin Dashboard using a mobile device or desktop computer.

1. Move the Power I/O (on/off) switch to the I (on) position.
 - The Pickup Pod will connect automatically to the Minnow cloud software in approximately 8–10 minutes.
2. For detailed administrator/owner setup and operation information, access the link below:

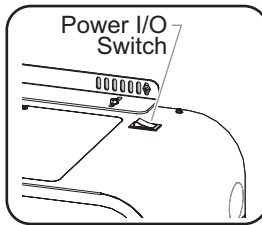

[Administrator/Owner Setup and Operation](#)

End User Operation

End users can pick up orders in one of two ways using a mobile device (smartphone or tablet):

1. Scan the QR Code on the front of the Pickup Pod, and follow the instructions that appear on the device screen.
2. Tap on the embedded link in the text message that was sent to the mobile device, and follow the instructions that appear on the device screen.

Delivery workers can deliver orders to the Pickup Pod by scanning the QR Code on the front of the Pickup Pod with a mobile device, and following the instructions that appear on the device screen.

For detailed end user setup and operation information, access the link below:

[End User Setup and Operation](#)

General

Minnow Pickup Pods are designed for maximum durability and performance with minimum maintenance.



ELECTRIC SHOCK HAZARD:

- Turn OFF power switch and unplug power cord before performing any cleaning, adjustments, or maintenance.
- DO NOT submerge or saturate with water. Unit is not waterproof. Do not operate if unit has been submerged or saturated with water.
- Do not steam clean or use excessive water on unit.
- This unit is not “jet-proof” construction. Do not use jet-clean spray to clean this unit.
- Do not clean unit when it is energized.
- Do not clean unit with metal scouring pads. Metal pieces can break off pad and touch electrical components, creating risk of electric shock.
- This unit must be serviced by qualified personnel only. Service by unqualified personnel may lead to electric shock or burn.
- Use only Genuine Minnow/Hatco Replacement Parts when service is required. Failure to use Genuine Minnow/Hatco Replacement Parts will void all warranties and may subject operators of the equipment to hazardous electrical voltage, resulting in electrical shock or burn. Genuine Minnow/Hatco Replacement Parts are specified to operate safely in the environments in which they are used. Some aftermarket or generic replacement parts do not have the characteristics that will allow them to operate safely in Minnow/Hatco equipment.

FIRE HAZARD AND ELECTRIC SHOCK HAZARD: Replace power cord with Minnow/Hatco Replacement Part 02.18.757.00 only.

This unit has no “user-serviceable” parts. If service is required on this unit, contact Minnow at: support@minnowpod.com



Do not move or relocate unit for cleaning. Unit is bulky and heavy.

Never use steel pads, wire brushes, or scrapers to clean unit.

Daily Cleaning

To maintain performance and preserve the finish of the unit, clean the Pickup Pod on a daily basis. Heavy use may require that the unit be cleaned more frequently.



Use non-abrasive cleaners and cloths only. Abrasive cleaners and cloths could scratch finish of unit, marring its appearance and making it susceptible to soil accumulation. DO NOT use cleaners such as acetone, Soft Scrub®, Bar Keepers Friend®, etc.

1. Move the Power I/O (on/off) switch to the **O** (off) position, and unplug the unit.
2. Clean the interior of each locker using a damp non-abrasive cloth or nylon scouring pad (a non-abrasive cleaner may be used for difficult stains).
3. Remove any spillages from lockers using damp paper towel or a non-abrasive cloth.
4. Wipe down all exterior surfaces using a non-abrasive, damp cloth (a non-abrasive cleaner may be used for difficult stains).
5. Wipe dry all surfaces using a non-abrasive, dry cloth.
6. Sanitize the interior of each cubby as well as all exterior surfaces, if desired.

**WARNING**

This unit must be serviced by qualified personnel only. Service by unqualified personnel may lead to electric shock or burn.

**WARNING**

ELECTRIC SHOCK HAZARD: Turn OFF power switch, and unplug power cord before performing any cleaning, adjustments, or maintenance.

Symptom	Probable Cause	Corrective Action
Unit does not power on.	Power I/O (on/off) switch in O (Off) position.	Move Power I/O (on/off) switch to the I (On) position. The switch will illuminate when in the I position and the unit is receiving power.
	Unit unplugged.	Make sure unit is plugged in.
	Unit connected to incorrect power supply.	Refer to SPECIFICATIONS section for unit electrical specifications. Contact a qualified electrician to determine and install proper voltage and size electrical receptacle.
Unit not connecting to internet.	Unit still connecting to Minnow cloud software.	Wait at least 10 minutes after moving Power switch to the I (On) position for the unit to connect and operate.
	Antennas not positioned properly.	Refer to the “Finishing Installation of the Pickup Pod” procedure in the INSTALLATION section of this manual for proper antenna alignment.
	Unit not configured for type of network connection that is in place (cellular, WiFi, or ethernet)..	Refer to “Connecting the Pickup Pod to the Internet” in the INSTALLATION section of this manual.
	Network connection is down.	Contact the appropriate network connection provider for information.
	Unit located in area with poor cellular reception.	Change to either a WiFi or ethernet network connection; or relocate unit to an area with a cellular signal of three bars or higher for all major mobile service providers.
Cubby door(s) won't open.	No power to unit or network connection is down.	Refer to symptoms “Unit does not power on” and “Unit not connecting to internet” in this table for corrective actions. If the above does not work, open the cubby doors manually: <ol style="list-style-type: none"> Remove the two (2) screws that secure the top access panel to the unit. Remove the panel. WARNING! ELECTRIC SHOCK HAZARD—Make sure power switch is OFF and unit is unplugged before removing panel. Pull up on the door release ring located just below the front, center of the top opening (refer to the “Opening the Cubby Doors” illustration in the INSTALLATION section). All the cubby doors will open.

Troubleshooting Questions?

If you continue to have problems resolving an issue, please contact Minnow for assistance at:

Telephone: 503-897-9061

email: support@minnowpod.com

For additional troubleshooting, frequently asked questions (FAQs), and general information, refer to the Minnow Help Center:

www.minnowpod.com/support/

LIMITED WARRANTY

WARRANTY, EXCLUSIVE REMEDY:

Minnow Technologies, Inc. ("Seller") warrants that the Pods will be free from defects in materials and workmanship under normal use and service and when stored, maintained, and installed in strict accordance with Seller's instructions. Seller's sole obligation to Customer (the person or entity buying the Pods directly from Seller) under this warranty is the repair or replacement by Seller or a Seller-authorized service agency, at Seller's option, of any Pod or any part thereof deemed defective upon Seller's examination, for a period of the Warranty Duration from the date of shipment by Seller. The "Warranty Duration" shall mean eighteen (18) months if Customer purchased the Pods or, if Customer is leasing the Pods, for so long as Customer leases the Pods. Credit for Pods or parts returned with the prior written permission of Seller will be subject to the terms shown on Seller's material return authorization form. **PRODUCTS OR PARTS RETURNED WITHOUT PRIOR WRITTEN PERMISSION OF SELLER WILL NOT BE ACCEPTED FOR CREDIT.** Expenses incurred by Customer in returning, replacing or removing the Pods will not be reimbursed by Seller. If the defect comes under the terms of the limited warranty, the Pods will be repaired or replaced and returned to the Customer and the cost of return freight will be paid by Seller. The remedy of repair or replacement provided for herein is Customer's exclusive remedy. Any improper use, alteration, repairs, tampering, misapplication, improper installation, application of improper voltage or any other action or inaction by Customer or others (including the use of any unauthorized service agency) that in Seller's sole judgment adversely affects the Pod shall void this warranty. The warranty expressly provided herein may only be asserted by Customer and may not be asserted by Customer's customers or other users of the Pods. **THIS LIMITED WARRANTY IS EXCLUSIVE AND IS IN LIEU OF ANY OTHER WARRANTY, EXPRESSED OR IMPLIED, INCLUDING BUT NOT LIMITED TO ANY IMPLIED WARRANTY OF NONINFRINGEMENT, MERCHANTABILITY OR FITNESS FOR A PARTICULAR PURPOSE, WHICH ARE EXPRESSLY DISCLAIMED.**

Notwithstanding anything herein to the contrary, the limited warranty herein will not cover components in Seller's sole discretion such as, but not limited to, light bulbs, lamp bulbs, LED lights, glass components, and fuses.

WARRANTY REGISTRATION INSTRUCTIONS:

A Pickup Pod must be registered within 90 days from the date of shipment from the factory to qualify for additional coverage. To register a Pickup Pod, scan the QR code on the front of the pod with a smartphone or other mobile device (after removing the pod from the shipping container, and before installing the pod) and follow the instructions on your smartphone or other mobile device.

LIMITATION OF LIABILITY:

SELLER WILL NOT BE LIABLE FOR ANY INDIRECT, INCIDENTAL, CONSEQUENTIAL, PUNITIVE, EXEMPLARY, OR SPECIAL DAMAGES, INCLUDING WITHOUT LIMITATION ANY LOST PROFITS, COSTS OF SUBSTITUTE PRODUCTS, OR LABOR COSTS ARISING FROM THE SALE, USE, OR INSTALLATION OF THE PRODUCTS, FROM THE PRODUCTS BEING INCORPORATED INTO OR BECOMING A COMPONENT OF ANOTHER PRODUCT, OR FROM ANY OTHER CAUSE WHATSOEVER, WHETHER BASED ON WARRANTY (EXPRESSED OR IMPLIED) OR OTHERWISE BASED ON CONTRACT, TORT, OR ANY OTHER THEORY OF LIABILITY, AND REGARDLESS OF ANY ADVICE OR REPRESENTATIONS THAT MAY HAVE BEEN RENDERED BY SELLER CONCERNING THE SALE, USE, OR INSTALLATION OF THE PRODUCTS, EVEN IF SELLER IS AWARE OF THE POSSIBILITY OF SUCH DAMAGES. IN NO EVENT WILL SELLER'S AGGREGATE LIABILITY ARISING OUT OF OR RELATED TO THIS AGREEMENT EXCEED THE TOTAL AMOUNTS PAID TO SELLER BY CUSTOMER FOR THE PRODUCTS WITHIN THE THREE (3) MONTH PERIOD IMMEDIATELY PRECEDING THE EVENT GIVING RISE TO CUSTOMER'S CLAIM. THE LIMITATIONS SET FORTH HEREIN REGARDING SELLER'S LIABILITY SHALL BE VALID AND ENFORCEABLE NOTWITHSTANDING A FAILURE OF ESSENTIAL PURPOSE OF THE LIMITED REMEDY SPECIFIED IN THESE TERMS.

Seller reserves the right to update these Terms at any time, at its sole discretion, which become binding upon the date of publishing.

Minnow Technologies
503-897-9061
support@minnowpod.com
www.minnowpod.com/support
www.minnowpod.com

HATCO CORPORATION
P.O. Box 340500
Milwaukee, WI 53234-0500 U.S.A.
800-558-0607 414-671-6350
support@hatcocorp.com
www.hatcocorp.com